



INSTALLATION INSTRUCTIONS

Electric - Direct Drive

PLEASE READ ENTIRE INSTRUCTIONS BEFORE BEGINNING

Step 1: Rolltube Bracket Installation

(See Figure 1-2)

Procedure: Position the driver and passenger rolltube brackets (A) along the front sides of the gravel box. The brackets should be mounted at a distance of 7" higher than the top of the box (see Figure 2).

Using a 9/32" drill bit, drill 3 holes through the predrilled holes in the brackets and through the box. Fasten the driver and passenger rolltube brackets to the box with the 5/16"x1" self threading bolts (B) provided.

Note: If the brackets are to be mounted to the wood side boards then drill 5 holes through the predrilled holes in the bracket and through the wood side boards. Fasten the brackets to the wood side boards with the 5/16"x2-1/2" hex bolts, 3/8" flat washers, and 5/16" nylon lock nuts provided.

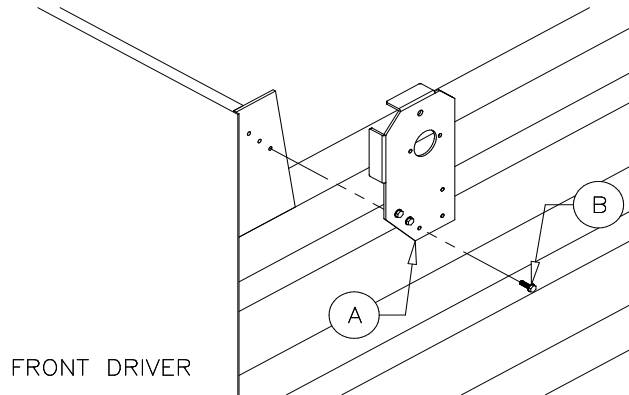

FRONT DRIVER

Figure 1

Step 2: Rolltube Installation

(See Figure 3-4)

Procedure: Slide the rolltube (C) through the large pocket at the front of the tarp. Insert the 1" rolltube end through the large hole in the driver side rolltube bracket. Slide the round flanges (F) and the UC205-16 self aligning bearing (G) on the rolltube end (C). Fasten the flange to the roll tube bracket with the 5/16" x 1" carriage bolts (J) and 5/16" nylon lock nuts. Next slide the electric motor into the rolltube and bolt to the rolltube bracket with 5/16"x3/4" bolts (N) and lock washers (O). Center the 2" pipe of the rolltube between the boards and then align the nearest hole in the rolltube with motor and secure with a 5/16"x2-1/4" bolt (M) and nylon lock nut (L). Tighten the set screw in the UC205-16 bearings (G).

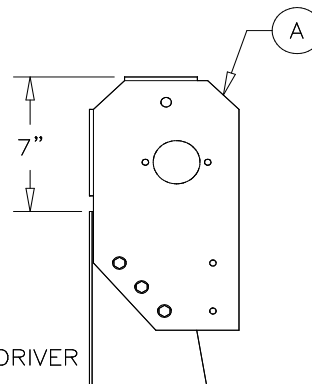

FRONT DRIVER

Figure 2

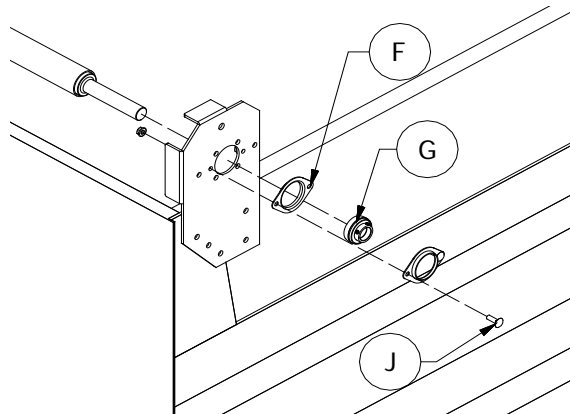

Figure 3

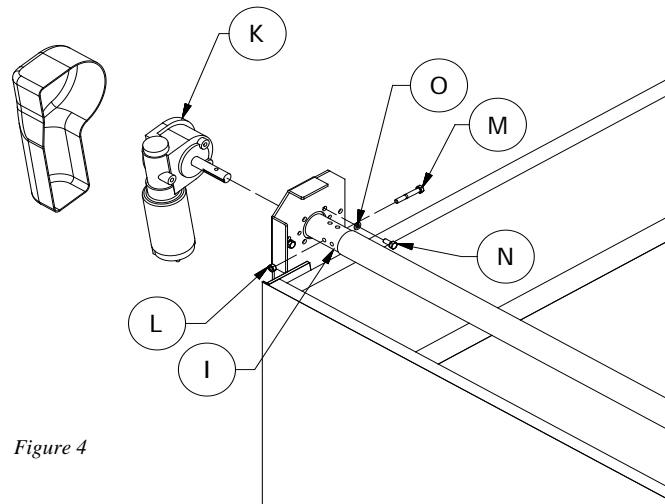

Figure 4

Step 3: Tarp Installation

(See Figure 5)

Procedure: Center the tarp on the rolltube between the boards. Remove any creases in the tarp along the rolltube. Position a pvc front clamp (D) on both edges of the tarp material. Fasten both tarp clamps to the tarp and the rolltube with the #10-24x3/4" wafer head screws (E) provided. Center the remaining two pvc front tarp clamps to the tarp material and rolltube.

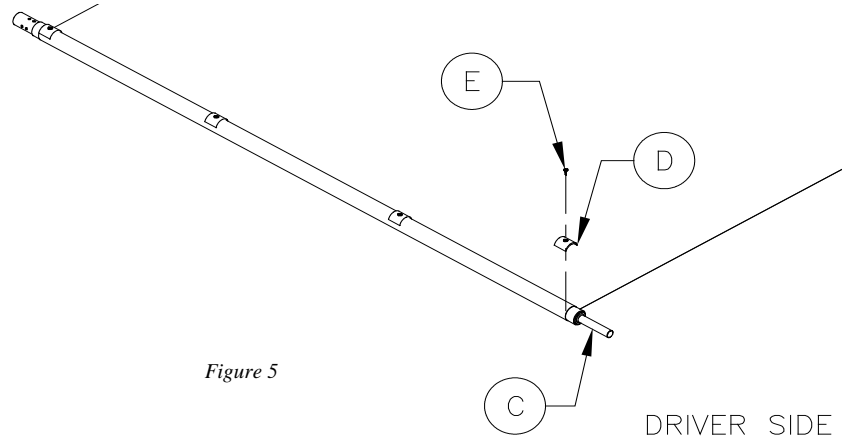

Figure 5

Step 4: Electrical Installation

Note: Apply the supplied Dielectric Lubricant to all wire connections when each wire is hooked up. The Dielectric Lubricant will help to prevent corrosion.

(See Figure 6)

Procedure: Mount the 2 pole connector on the front of the trailer. Note: If tarp is not going on a trailer, the 2 pole connector is not needed. Run #6 double strand wire from the motor posts down the front, back to the hinge point of the box, and along the frame to the 2 pole connector. Secure the wire with the wire clips and lags provided. Install the motor cover on the motor and secure with (2) #10x1/2" screws. Mount the rocker switch in the dash or an obstruction free area in the truck cab. Mount the solenoid near the cab and the battery of the truck. Run #6 double strand wires from the solenoid along the truck frame to the 2 pole male connector at the back of the truck. Connect the motor wires to the "IN" & "OUT" on the solenoid. Install a black rubber boot on each wire. If not on a trailer, the #6 double strand wire would run straight from the motor to the solenoid. Run #6 double strand wire from the solenoid to the battery. Connect the positive red wire to the "+" post on the solenoid along with a red rubber boot and connect the negative wire to the "-" post with a black rubber boot. Install a 50amp circuit breaker in line with the positive wire. Run 14G-3 wire from the solenoid to the switch in the cab. The wires at the switch each get 14G female connectors crimped on. At the solenoid the 14G-3 wire gets (2) 14G female connectors and (1) 14G-1/4" ring terminal crimped on. The ring terminal is mounted on the battery positive (+) post of the solenoid. NOTE: If the motor runs backwards, switch the (2) outside wires on the switch. Raise and lower the hoist to make sure that the wires are free from obstructions.

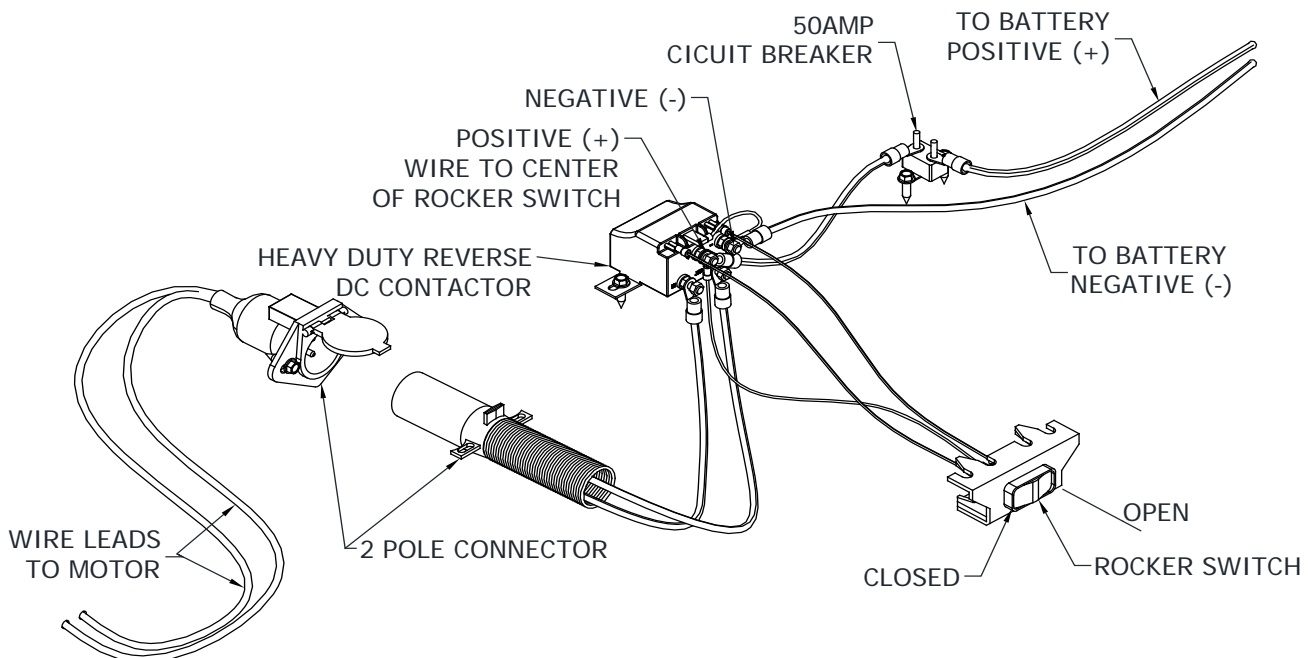

Figure 6

Step 5: Pivot Arm Installation

(See Figure 8-17)

Procedure: Measure from Point A (see Figure 8) to a point on the lower inside rib of the box that is close to the pivot point (see Figure 9). Mark this point and record the distance as X. Using distance X, measure from Point B (see Figure 10) to a point on the lower inside rib of the box (see Figure 9). Mark this point.

To install the rear lock there needs to be 6" of room behind Point B. (shown in figure 10)

Divide the distance between the first and second mark by two and mark this point as the pivot point (see Figure 9).

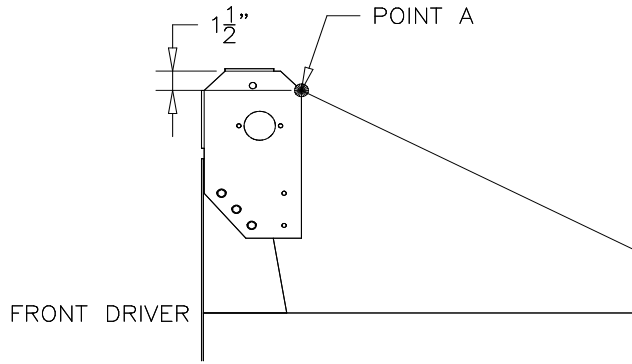

Figure 8

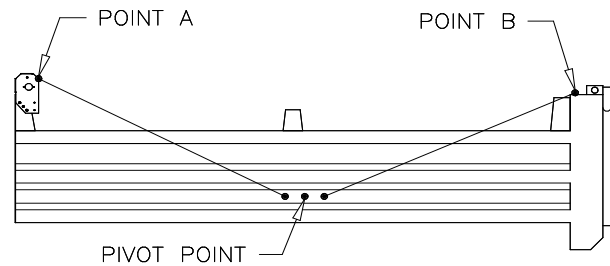

Figure 9

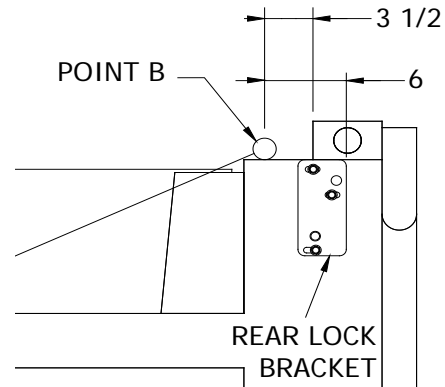

Figure 10

Align the pivot arm bracket (T) with the pivot point.

Note: The pivot arm end (U) must be aligned with the pivot point.

Using a 3/8" drill bit, drill through the center of the slots in the bracket (T) and through the box wall. Fasten the pivot arm bracket to the box with the 3/8"x1-1/2" hex bolt (V), 3/8" flat washers, and 3/8" nylon lock nuts provided (see Figure 11).

Slide the helical torsion spring (B), bottom pivot arm (C), and 3/4" flat washer (D) on the pivot arm end (U). Insert and lock the cotter pin (E) (see Figure 12).

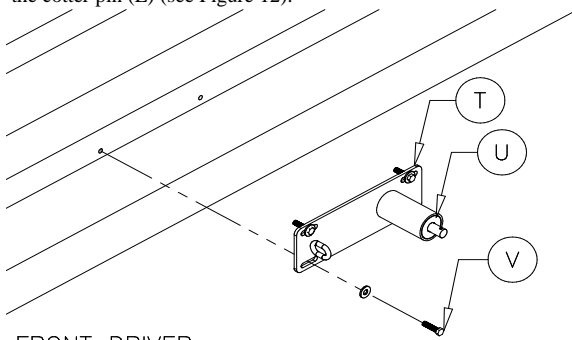

FRONT DRIVER

Figure 11

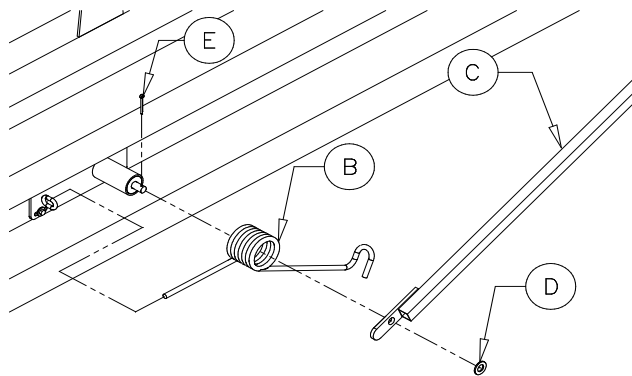

Figure 12

Step 5: Pivot Arm Installation Con't

Note: The bottom pivot arm (C) may have to be shortened depending on the length of the box.

Position the bottom pivot arm (C) so it is hooked in the helical torsion spring (B) (see Figure 13). Repeat the above procedure for the opposite side of the box.

Slide the rear pivot arm crossmember (F) through the rear tarp pocket. Position the rear pivot arm crossmember at Point B (see Figure 13 & 17).

Slide the top pivot arm (G) into the bottom pivot arm (C). Rotate the pivot arm towards the top of the box. Insert the 1" OD. pipe on the top pivot arm into the rear pivot arm crossmember (F). Repeat for the opposite side of the box.

Note: The 1"OD. pipe welded to the top pivot arm (C) may have to be shortened.

Adjust the rear pivot arm crossmember (F) and the top pivot arms (G) so they are at Point B (see Figure 10 & 14).

Note: Make sure that the distance the top pivot arm protrudes out of the bottom pivot arm is equal on both sides of the box.

Using a 5/16" drill bit, drill through the bottom and top pivot arm on both sides of the box. Secure the pivot arms with the 5/16"x1-3/4" hex bolt (H) and 5/16" nylon lock nut provided (see Figure 14). Adjust the pivot arms so they are aligned with the sides of the box.

Rotate the rear pivot arm crossmember (F) so that the crossmember guides (I) are resting on the top of the box with the crossmember (see Figure 18). Using a 5/16" drill bit, drill through the pivot arm crossmember (F) and top pivot arm (G). Secure the pivot arm crossmember to the top pivot arms with the 5/16"x1-3/4" hex bolts (H) and 5/16" nylon lock nuts provided (see Figure 16).

Note: Allow a great enough distance between the box wall and the pivot arm, in order to install the pivot arm guides on both sides of the box (see Step 6).

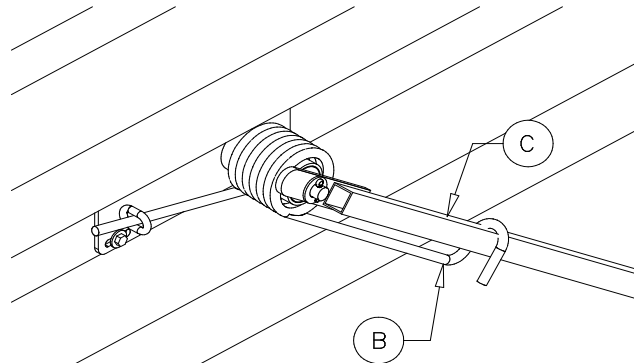

Figure 13

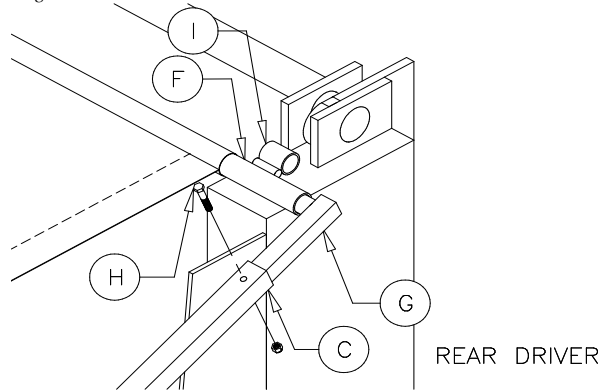

Figure 14

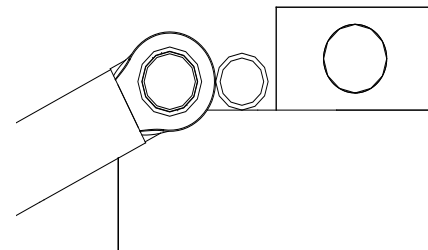

Figure 15

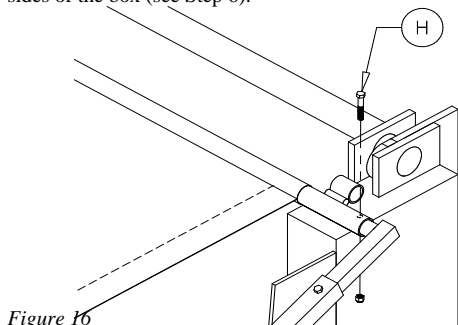

Figure 16

Center the rear tarp pocket on the rear pivot arm crossmember (F). Position a pvc rear tarp clamp (J) on both edges of the tarp material. Fasten both tarp clamps to the tarp and rear pivot arm crossmember (F) with the #10-24x3-4 wafer head screws (K) provided (see Figure 20).

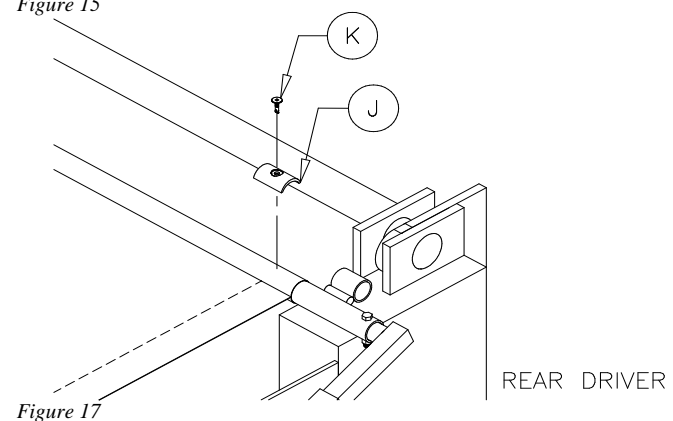

Figure 17

Step 6: Pivot Arm Guide Installation

(See Figure 21-22)

Note: The pivot arm guides (L) (see Figure 21) prevent the tarp from shifting to either side of the box when the tarp is in closed position.

Procedure: Close the tarp. Place a pivot arm guide (L) along one of the ribs in the box wall (see Figure 22). Make sure the guide is aligned with the pivot arm (C) (see Figure 22). Mark the position of the pivot arm guide. Using a 9/32" drill bit, drill two holes into the box wall. Secure the pivot arm guide to the box wall with the 5/16"x1" self threading bolts provided.

Repeat the above procedure for the opposite side of the box.

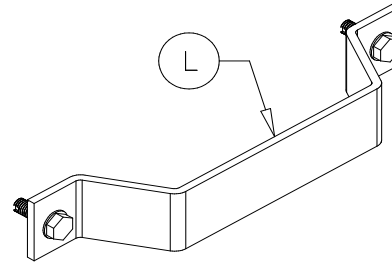

Figure 18

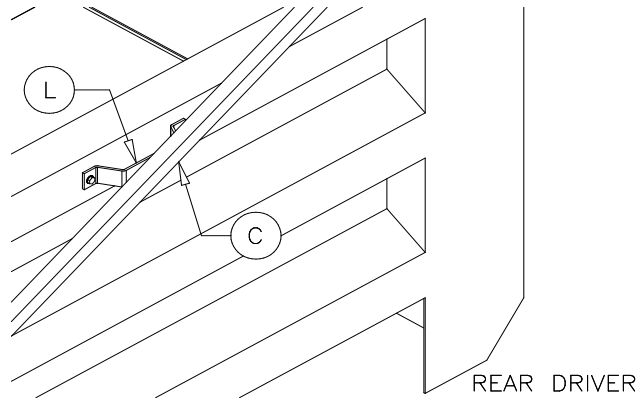

Figure 19

Step 7: Optional Front Hood Installation

(See Figure 20)

Procedure: Center the front hood (M) on the driver and passenger rolltube brackets (A). Using a 3/16" drill bit, drill one hole through the front hood and into the top flange on each rolltube bracket. Drill two 3/16" holes through the front hood and into the front flange on each rolltube bracket. Fasten the front hood to the brackets with the 1/4"x1" lag screws (N) provided.

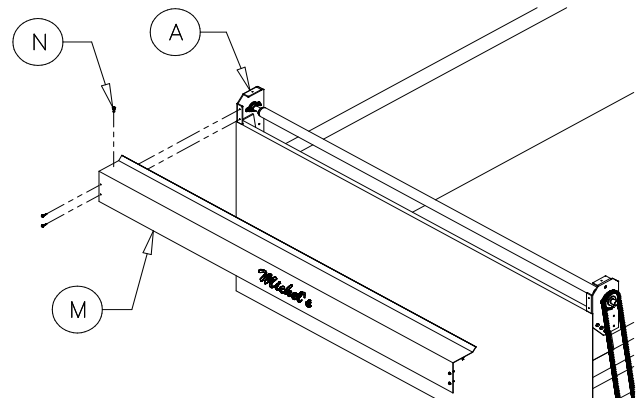

Figure 20

Warranty Michel's Industries warrants their products for a period of one year from date of purchase. Any parts returned to Michel's Industries LTD. Will

FOR INSTALLATION ASSISTANCE PLEASE CALL COLLECT (306) 366-2184

Michel's Industries LTD.
PO Box 119
St. Gregor Sk S0K 3X0

Step 8: Rear Lock Installation

(See Figure 22-32)

Mount the rear driver lock bracket (A) to the back post of the trailer shown here.

Place the bracket so the front edge of the bracket is inline with the center of the short pipes welded on the rear crossmember and the top of it is the same height as the bottom of the pipes.

Mark your holes in the center of the slots and drill an 11/32" at your marks.

Secure the rear driver lock bracket to the trailer with 3/8"x1-1/4" self-threading bolts.

Slide the plastic latch (B) onto the mounting pin (A-1) (shortest one with a hole in it) on the driver rear bracket. The side with the collar on it goes to the inside so both posts stick outwards from the trailer. Secure on with a 3/4" machinery bushing and 1/8" cotter pin.

Measure the width of the box where you will be installing the lock components.

Cut the aluminum hex shaft (C) at the width of the box + 4-1/4".

Slide the shaft into the rear crossmember pipes.

Slide the hex locking collars (D) onto the ends of the hex shaft and into the pipes on the crossmember. Slide them on so the setscrews are on the same faces of the hex shaft.

Center the hex shaft so 2-1/8" sit out each side of the box and tighten the setscrews in the hex collars preventing it from moving side to side.

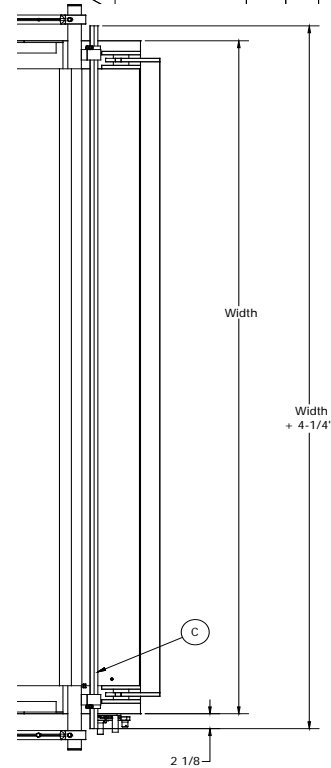
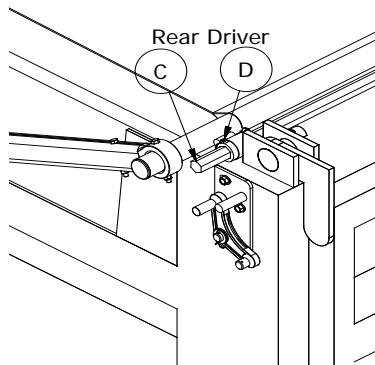
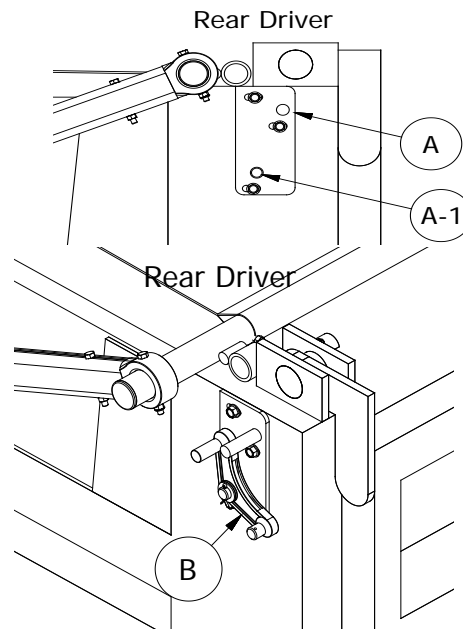

Slide a rear hook (E) onto each end of the hex shaft so they are flush to ends and are positioned the same. Secure the rear hooks to the hex shaft by tightening the setscrews in them.

Rotate the hex shaft so the rear hook locks under the pin (A-2) on the driver bracket. You may need to adjust the driver bracket so the rod sits in the hook as shown here.

Have the latch so the largest post on it is pushing up against the rear hook as shown here.

Place the plastic rod connector (F) onto the latch and secure with 3/4" machinery bushing and 1/8" cotter pin.

Place the short leg of the aluminum connecting rod (G) into the handle assembly (H). Use the lynch pin (I) to keep the handle assembly in the locked position shown here.

Locked Position

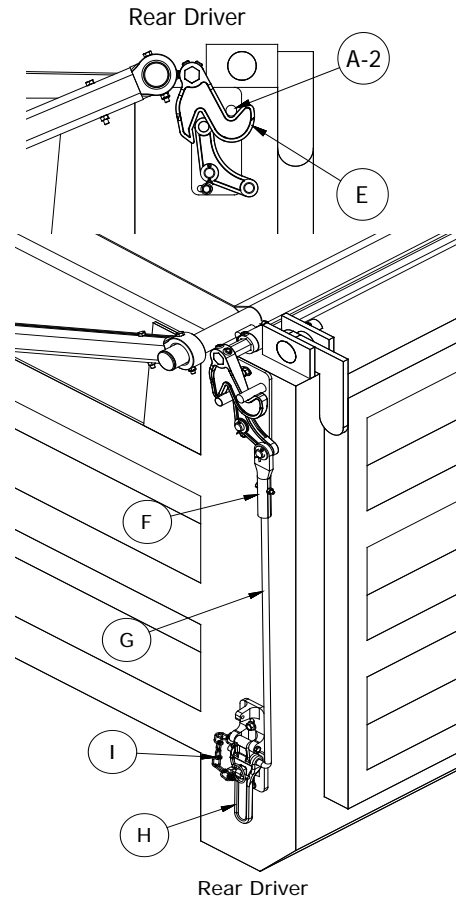
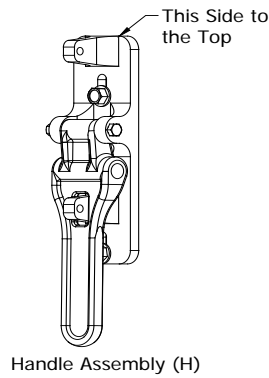

Next slide the long leg of the aluminum connecting rod into the rod connector while having the locking handle flush up against the trailer. The aluminum rod may need to be shortened.

With the aluminum connecting rod at the necessary length secure it to the rod connector. Make sure the aluminum rod is all the way into the rod connector.

Drill a 1/4" hole through both of them and bolt together with a 1/4"x1-1/2" bolt and nylon lock nut. The aluminum connecting rod has to be positioned so the short leg is running parallel with the side of the box. Drill the hole through them so the bolt runs the length of the box preventing it from rubbing the side of the trailer.

Once secured make sure the hook is fully locked under the locking pin with the latch pushing up against it and place the handle assembly against the side of the box. The back face of the latch handle should be 1/2" in from the back face of the driver lock bracket.

Mark the bottom of the top slot in the handle assembly

Drill a 11/32" hole at your mark and secure the handle assembly to the trailer with a 3/8"x1-1/4" self threading bolt.

Remove the lynch pin from the handle allowing the handle to rotate up.

With the handle assembly sitting vertically drill a 11/32" hole at the bottom of the bottom slot and secure with a 3/8"x1-1/4" self threading bolt.

Rotate the handle down so the hook locks and you can put the lynch pin back in the handle preventing it from unlocking. You should have to apply a little force to lock the handle and should snap locked when over centered. If this doesn't happen, loosen the (2) bolts securing the handle to the trailer and move the handle downwards and retighten the bolts. You do not want to have excess tension on the handle when locking it.

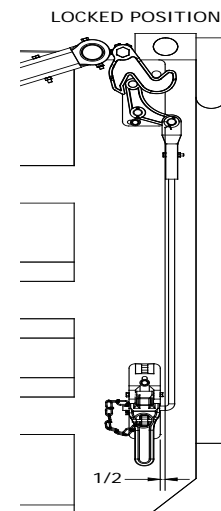

With the driver side hook locked under the pin, place the passenger side lock bracket (J) against the trailer so the locking pin sits in the hook like the driver side.

Mark the center of the top slot and drill a 11/32" hole at your mark.

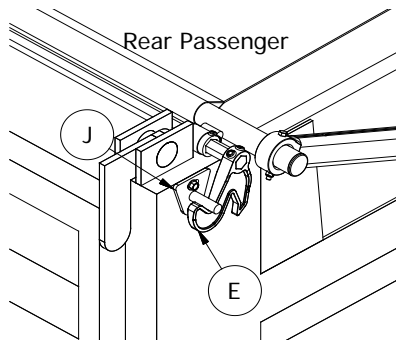

Go to the driver side and unlock the tarp but rotating the handle up and using the lynch pin to secure it in the unlock position.

Secure the bracket to the trailer with a 3/8"x1-1/4" self-threading bolt. Have the top of the bracket running parallel with the top of the trailer.

Drill an 11/32" hole in the middle of the bottom slot and secure with a 3/8"x1-1/4" self threading bolt.

Lock the hooks under the locking pins and adjust the passenger side if necessary.

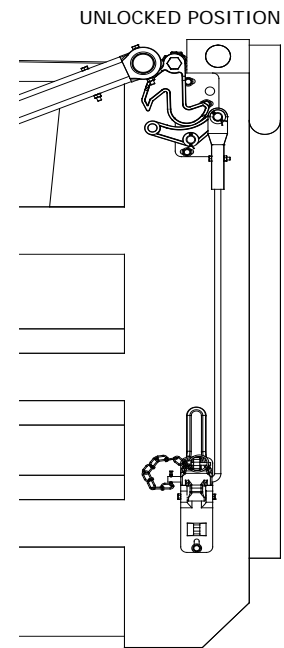

Note: For the lock to work properly the pivot arm guides need to be installed and provide very little side to side movement when closed so the rear lock components line up properly.

PLEASE PHONE MICHEL'S INDUSTRIES FOR ASSISTANCE (306) 366-2184.

*******IMPORTANT NOTICE*******

WARRANTY WILL BE VOID IF:

- **The motor cover is not installed**
The cover prevents moisture and dust from accumulating inside the motor
- **The motor terminals are over tightened**
Over tightening the motor terminals will cause the brush holder to break or crack.

Operating Instructions

Opening Tarp – To open the tarp so it is fully rolled up on the front rolltube to allow product to be dumped into the box, first unlock the rear lock if there is one installed. If installed, the tension should first be removed from the tarp by rotating the main crank clockwise. Then go to the rear of the trailer and remove the lynch pin holding the handle in the locked position. Rotate the handle up and use the lynch pin to secure the handle in the unlocked position. Go back to the front of the trailer and pull the handle of the crank and rotate it so the handle is sticking out from the box. Turn the crank counter clockwise to open the tarp. The locking handle on the crank will click on the sprocket and prevent the crank from spinning if you let go of the handle. Stop cranking when the tarp is completely rolled up on the front rolltube. Reposition the crank handle back into transport position so it will not be sticking out (shown below).

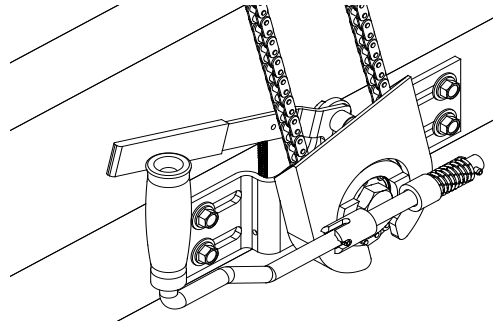

Closing Tarp – To cover your box, pull the crank handle and rotate it so the handle will be sticking out from the box. Firmly hold onto the crank handle and lift the locking handle up and slowly turn the crank clockwise to unroll the tarp. **CAUTION** The crank will want to spin clockwise on you since there is a high torque being applied to it. If you need to stop, lower the locking handle so it locks in the sprocket first and then let go of the handle. In case your hand slips off the crank handle, quickly let go of the locking handle and the tarp will stop. Unroll the tarp until the rear cross member is sitting on the back of the box. Once the rear crossmember is sitting on the top rail at the rear of the trailer, go to the rear and lock the tarp down if a lock is installed. If installed remove the lynch pin from the handle and rotate the handle downwards. This should cause the hooks to lock under the locking pins on the side of the box. Secure the handle in the locked position with the lynch pin. Go to the front and remove any slack in the tarp by cranking it counter clockwise.